

4 Lead Wire
13mm, 19mm L,
0.9° step

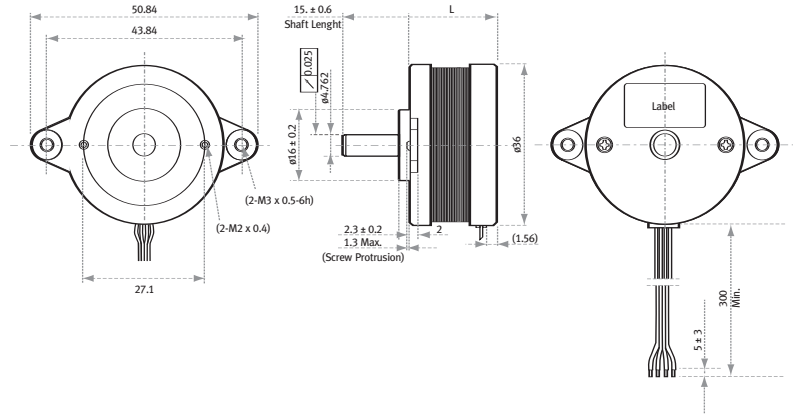

Mounting configuration for variable NEMA sizes

Specifications

MODEL	STEP ANGLE	VOLTAGE	CURRENT	RESISTANCE	INDUCTANCE	HOLDING TORQUE	ROTOR INERTIA	NUMBER OF LEADS	WEIGHT	DIMENSION
SINGLE SHAFT	DEG.	V	A/Phase	Ω/Phase	mH/Phase	kg-cm	g-cm ²	LEAD	kg	L
SST36C0030	0.9	5	0.30	16.8	8.5	0.36	7.3	4	0.05	12.35
SST36C1050	0.9	5	0.45	11.5	9	0.86	19	4	0.09	19.7

RoHS compliant

Typical Performance (Bi-polar)

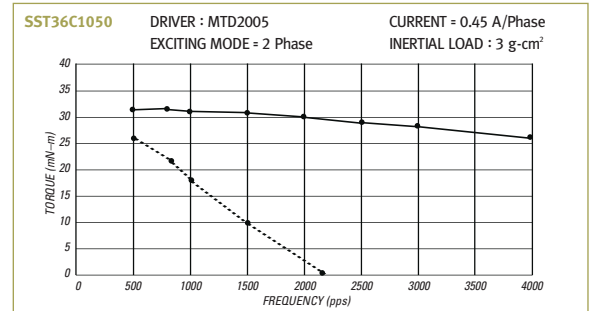
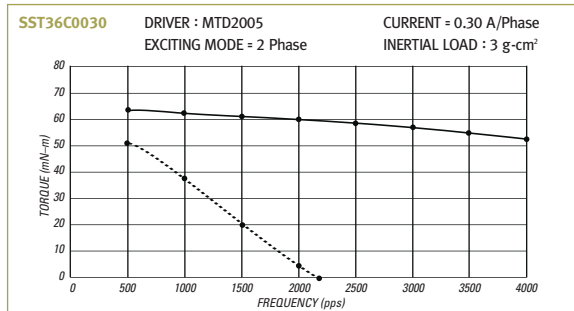

Refer to page 41 for Driver Information